

Design 7

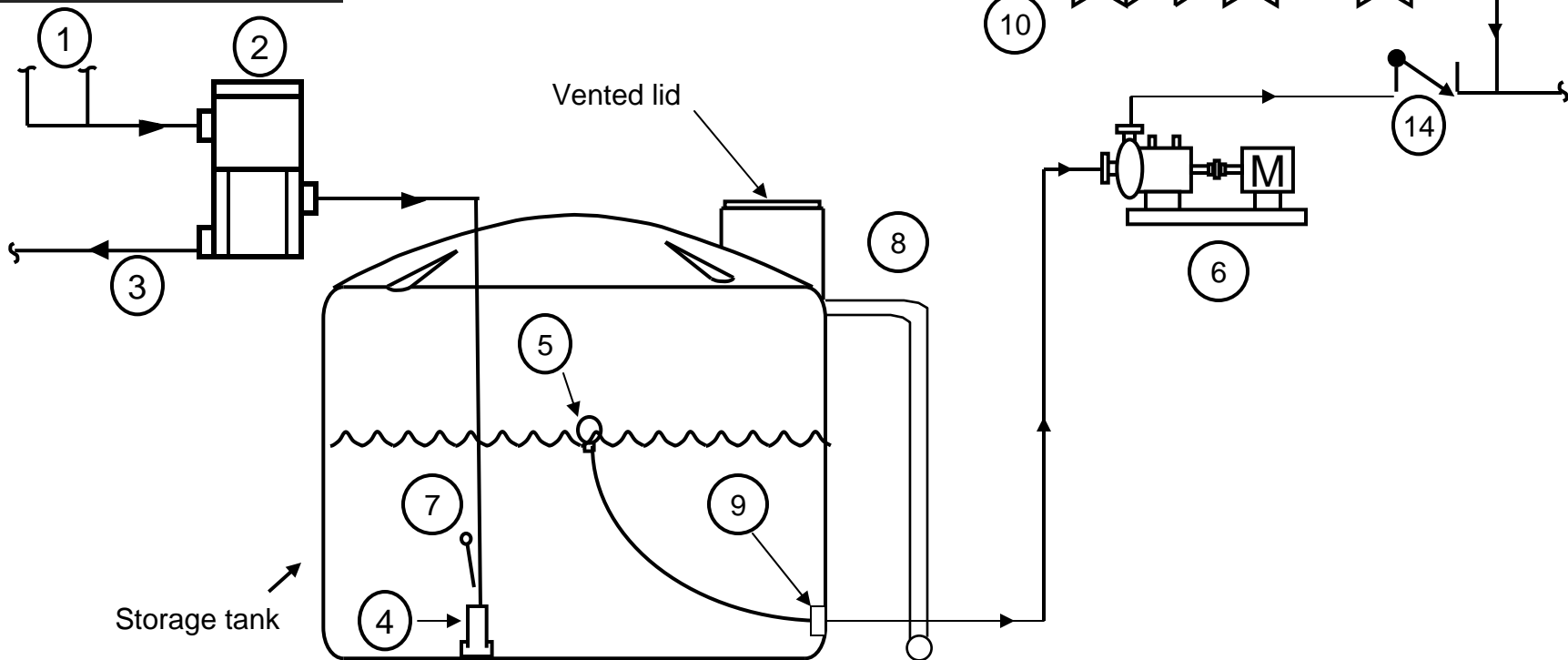

- | | | |
|-----------------------------------------------------------------------------------------------------------------------------------------------------------------------------------------------------------------|---------------------------------------------------------------------------------------------------------------------------------------------------------------------------------------------------------------------------------------------------------------------------|-------------------------------------------------------------------------------------------------------------------------------------------------------------------------------------------------------------|
| <p>1 Rainwater collection point (roof drains, gutters, etc)</p> <p>2 Rainwater enters the vortex filter and is processed. Mounted with Wall Bracket</p> <p>3 Remaining water from vortex filter to overflow</p> | <p>4 Smoothing inlet – stainless steel “flow-calming” device to eliminate turbulence of the incoming water as it enters the tank</p> <p>5 Floating stainless steel suction filter</p> <p>6 Jet pump</p> <p>7 Low water cut off float switch for pump protection (N/O)</p> | <p>8 Overflow</p> <p>9 Check valve</p> <p>10 Domestic water supply</p> <p>11 Backflow prevention device</p> <p>12 Pressure regulator valve set at 30 psi</p> <p>13 Pressure gauge</p> <p>14 Check valve</p> |
|-----------------------------------------------------------------------------------------------------------------------------------------------------------------------------------------------------------------|---------------------------------------------------------------------------------------------------------------------------------------------------------------------------------------------------------------------------------------------------------------------------|-------------------------------------------------------------------------------------------------------------------------------------------------------------------------------------------------------------|

RAINWATER HARVESTING SYSTEM DETAIL (For Design Only)

Not For Construction

NOT TO SCALE